

nylex

3yr
Warranty

Hose Hanger Post
50109812

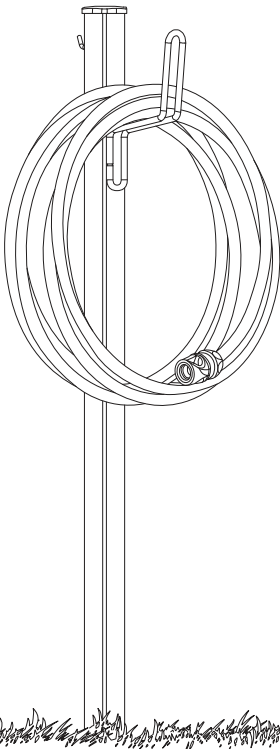

Hose Reel Mounting Post
Square
50109836

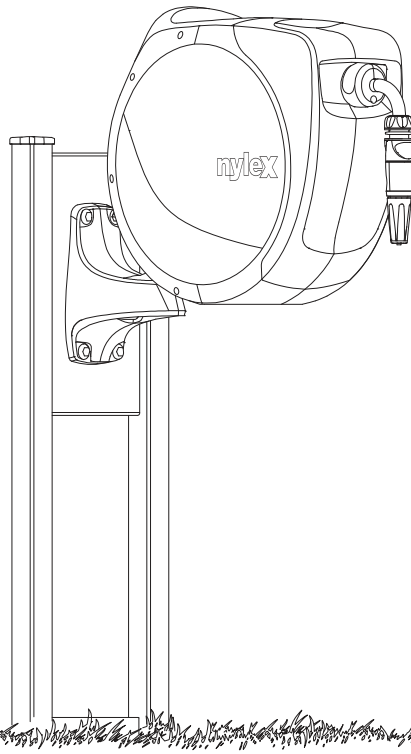

Hose Reel Mounting Post
Round
50109829

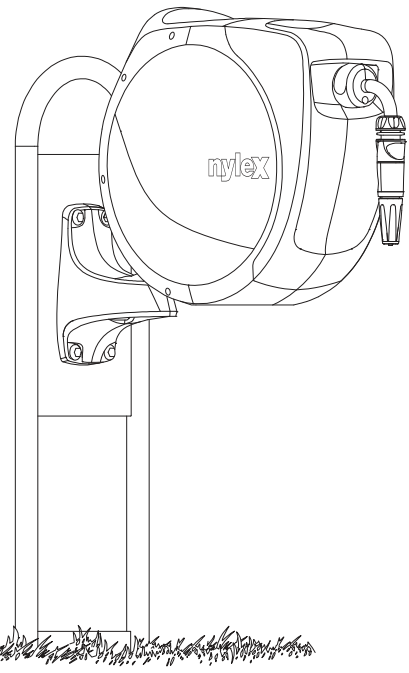

Mounting Post Installation Manual

Mounting Post Installation Manual

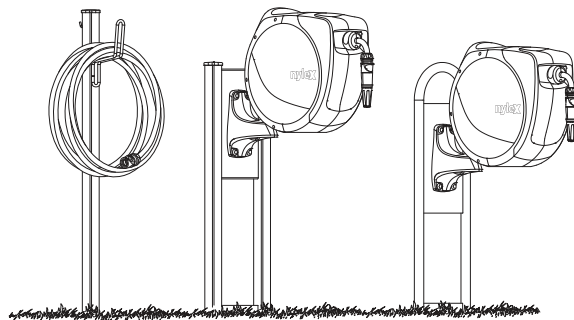

What You Will Need

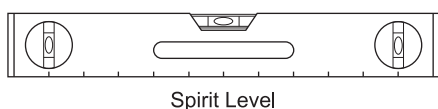

Spirit Level

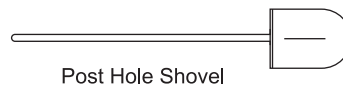
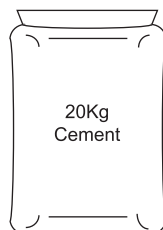

Post Hole Shovel



WARNING:

- Ensure there are no live electrical wires or plumbing in the ground at the location you are digging

INSTALLATION

1. Dig a hole 250mm in diameter and at a depth of 450mm
2. Fill bottom of hole with roughly 150mm of gravel (this will help with drainage)
3. Sit post roughly 300mm in the ground and ensure it is level
4. Fill hole with concrete (ensure holes in the base of the post are covered with concrete)
5. While the concrete is setting ensure that it remains level. It is also recommended to slope the top of the concrete away from the post (this will also help with drainage). Fill the last 100mm with soil
6. Around the bottom of the post can be decorated with grass, pebbles or plants if desired

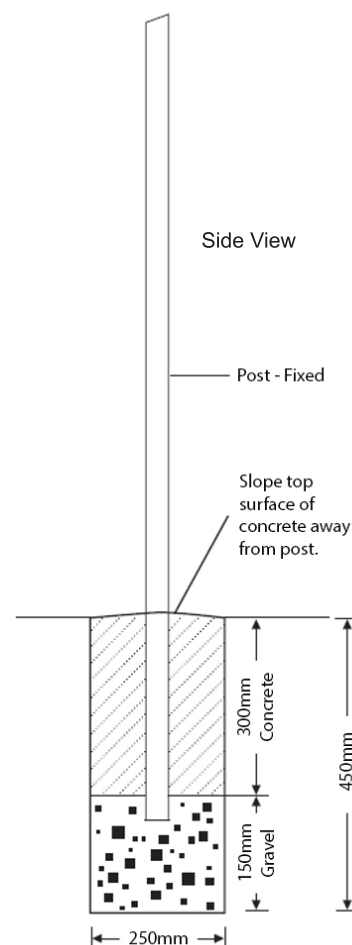

MOUNTING THE HOSE REEL BRACKET

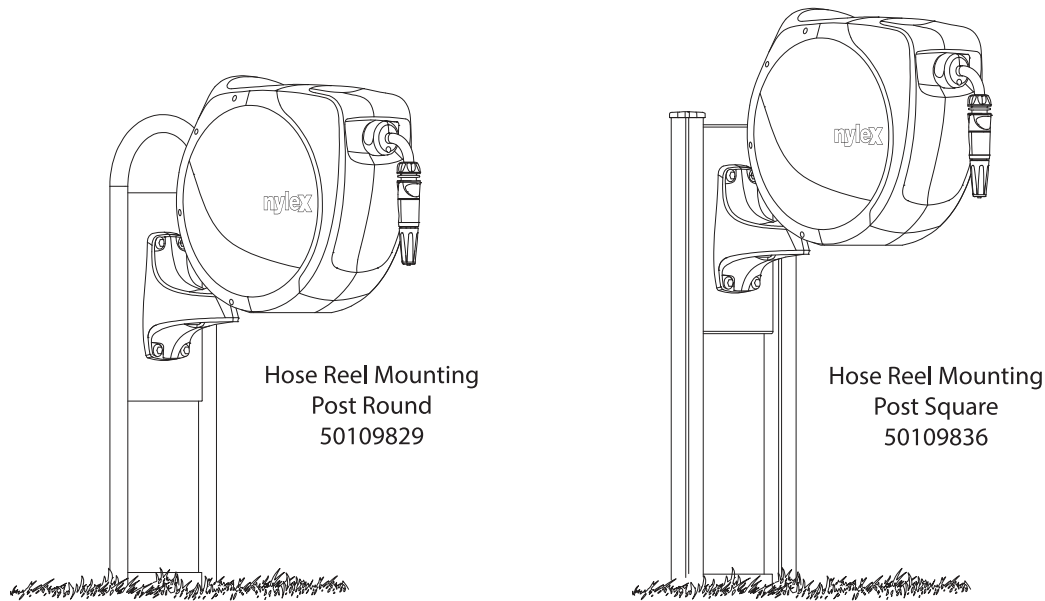

The Hose Reel Mounting Posts (items 50109829 & 50109836) come pre-drilled with holes that suit the Nylex 20m & 30m Retractable Hose Reels (items 701153 & 701177).

To mount the bracket of the hose reels to the post you will need 4x M6*40mm galvanised or stainless bolts and washers (sold separately).

Alternative Retractable Hose Reels and their brackets can be accommodated by drilling the required holes into the mounting plate.

NYLEX WARRANTY

AMES Australasia Pty Ltd (AMES) guarantees that this product will be free from defects in workmanship and materials for 3 years from the date of purchase. If such a defect becomes evident during that period, AMES will, at its option, either repair, replace or refund the product. In the event of such a defect, the product should be returned to the place of purchase (together with proof of purchase and the original packaging) at the address below. Any handling and transportation costs (and other expenses incurred in claiming under this guarantee) are not covered by this guarantee and will not be borne by AMES. The obligation of AMES under this guarantee is limited to the circumstances set out above and is subject to; the customer being able to evidence the acquisition of the product, the purchase price paid for the product and the relevant defect in materials or workmanship; the product not having been altered, tampered with or otherwise dealt with by any person in a manner other than as intended in respect of the relevant product; and the product not having been used or applied in a manner that is contrary to customary usage or application for the relevant product or contrary to any stated instructions or specifications of AMES. In addition to other rights and remedies that may be available under law, our goods come with guarantees that cannot be excluded under the Australian Consumer Law (for consumers in Australia) and the Consumer Guarantees Act (for consumers in NZ). If you are a consumer in Australia, you are entitled to a replacement or refund for a major failure and compensation for any other reasonably foreseeable loss or damage. You are also entitled to have the goods repaired or replaced if the goods fail to be of acceptable quality and the failure does not amount to a major failure. If you are a consumer in New Zealand, we will comply with our obligations to you under the Consumer Guarantees Act.

Call: (Australia) 1800 335 019 E-mail: nylex@amesau.com Address: Ames Australasia Pty Ltd, 1/660 Doncaster Road, Doncaster, Victoria, Australia, 3108.

